

# ELECTROMECHANICAL VIBRATORS

## Typical Mounting Instructions

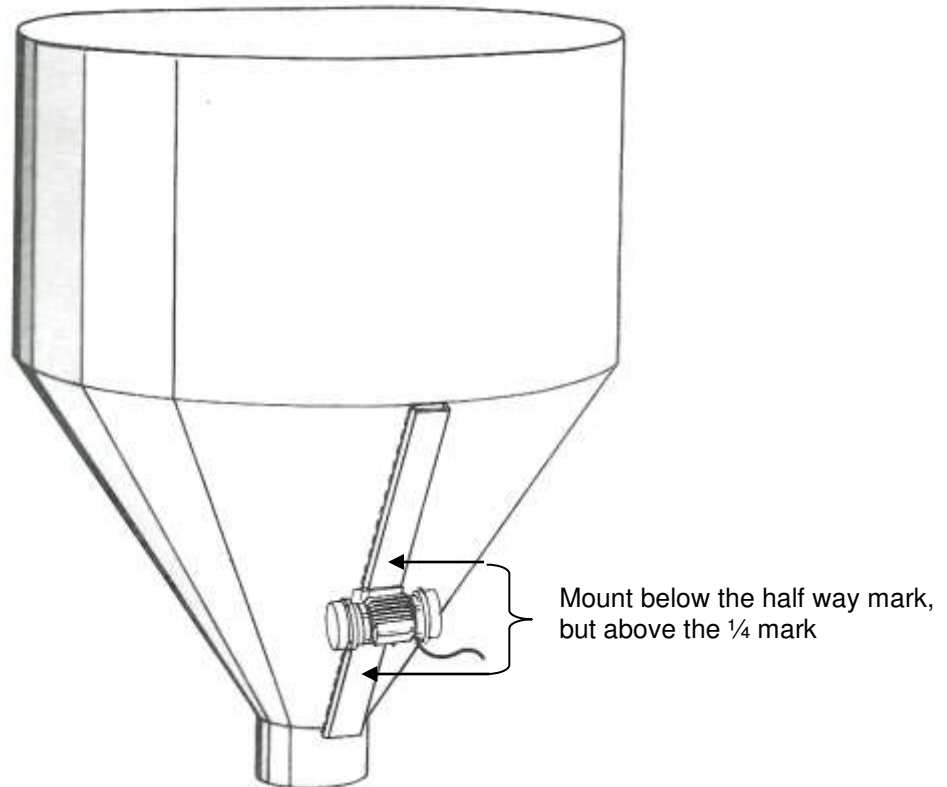

- A channel must be used for reinforcement when mounting an electromechanical vibrator.
- The reinforcement channel should extend the full length of the sloped section of the storage vessel.
- A plate may be welded to the channel and drilled to the bolt hole specification of the vibrator.
- The vibrator should be mounted in the bottom  $\frac{1}{2}$  to  $\frac{1}{4}$  of the sloped section (cone) of the storage vessel.
- For bolt hole dimensions, see bulletin 1000.201.
- For bolt and torque specifications, see bulletin 4000.504.