

NAVCO® BIN HOPPER (BH) VIBRATOR



NAVCO has been solving bulk material flow problems using pneumatic piston vibrators since 1955. Incorporating the most advanced manufacturing techniques, quality control, and bulk solids flow technology, NAVCO provides effective solutions utilizing reliable, field proven equipment.

NAVCO features technically-oriented field Representatives in cities across North America. These are veteran problem-solvers in material flow solutions. NAVCO does more than just manufacture vibrators, we design solutions to material flow problems – and we stand behind them!

Why use Pneumatic Piston Vibrators?

Linear Vibration – The forces generated by NAVCO BH Vibrators may be directed and concentrated in the problem area. The linear nature of the vibration force also ensures no damaging shear forces are applied to the mounting bracket or storage vessel.

High Amplitude, Low Frequency – The high-energy impulse vibration generated by NAVCO BH Vibrators is effective in reducing the strength of bulk materials and the sliding friction between the material and the bin wall. This is accomplished at low frequencies, without approaching potentially damaging resonant frequencies.

Low Cost – NAVCO pneumatic piston vibrators can effectively solve virtually any bulk material flow problem at a fraction of the cost of alternative solutions.

Low Maintenance – NAVCO pneumatic piston vibrators provide years of effective performance when installed and operated properly.

BH Vibrator Types

NAVCO BH Vibrators are available in ten different piston sizes to handle a wide range of bulk material flow problems. Each size is offered in three distinct types of operation:

Repetitive Impact BH Vibrator: Repetitive impacting units deliver a high-energy impulse with each stroke of the piston. The impacting model is the most effective of the three in eliminating difficult flow problems.

Single Impact BH Vibrator: Single impact models deliver a single high-energy impulse triggered by the output of a timer or other controlling device. Timed impact units are particularly effective in applications where dry materials adhere to vessel walls.

Silent BH Vibrator The silent units trap a cushion of air at the base of the piston, eliminating the impact. Although the air cushioned models are quieter, a larger size is normally required.

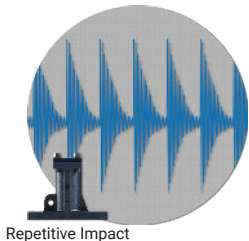

Repetitive Impact

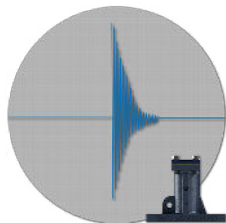

Single Impact

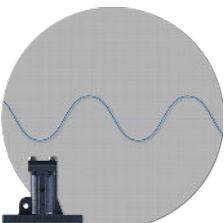

Silent

Sizing

Although there are numerous factors to consider in designing a flow aid system, there are general guidelines for vibrator sizing. The two primary considerations are the hopper size and wall thickness. The chart below will help in preliminarily sizing vibrators. For large, unusual or particularly difficult applications, please contact NAVCO directly at 832-467-3636.

Vibrator Size	BH 1.00	BH 1.25	BH 1.62	BH 2.00	BH 3.00	BH 3L	BH 4.00	BH 5.00	BH 6.00	BH 8.00
Hopper Capacity	0-3 ft ³	3-7 ft ³	7-20 ft ³	20-50 ft ³	5-20 ton	20-50 ton	50-100 ton	100-300 ton	300-1000 ton	800-1500 ton
Wall Thickness	1/16 - 1/8	1/16 - 1/8	3/16 - 1/4	3/16 - 1/4	1/4 - 3/8	1/4 - 3/8	3/8 - 1/2	3/8 - 1/2	3/8 - 1/2	1/2 - 3/4

Vibrator Accessories

Manual Valve - This can be utilized for manual operation or be placed upstream of the FRL to allow for isolation of the vibrator system from the air supply

Filter, Regulator, Lubricator - BH Vibrator units require a clean, dry, lubricated air supply to provide optimum operation and service life.

Solenoid Valve - Vibration is most effective when it is intermittent and when it is applied only when required. Solenoid valves control the vibrators electronically, and allow seamless integration into the existing process.

Flexible Hose - Flexible hose assemblies with close fitting NPT fittings should be used to make the direct connection to the vibrator.

Exhaust Protector - In corrosive or abrasive atmospheres, exhaust protectors may be used on vibrators with tapped exhaust ports to prevent internal contamination of the vibrator.

Pneumatic Timer - In applications where electricity is not available or allowable, a pneumatic timer may be used to provide intermittent operation.

Digital Cycle Timer - The timer allows for automating operation of single or multiple vibrators to ensure maximum efficiency and effectiveness of the vibrator installation.

Special Application Options

NAVCO BH Vibrators are available with several options for a variety of special operating conditions.

Tapped Exhaust - For dusty corrosive, underwater, or sanitary applications, tapped exhaust ports are available to protect the vibrator or to remove the exhaust from an area.

Internal Spring - Enables instantaneous starting for applications requiring the vibrator to operate in a horizontal orientation.

PTFE Coating - PTFE coating provides extra protection for vibrator units operating in highly corrosive or abrasive atmospheres.



T-Slotted Mount

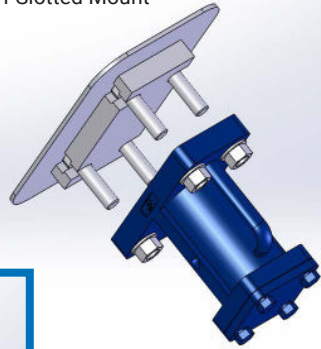

Channel Mount

Mounting Accessories

Channel Mount – Ideal mounting solution for most applications.

T-Slotted Mount – Alternative mounting solution for certain applications

Slip Mounting Bracket – For portable mounting of BH 1.62 & BH 2.00.

Pipe Mounting Bracket – Ideal for eliminating flow problems in pipes or tubing.

Conical Mounting Bracket - Installation solution for conical hoppers where welding is not permitted or possible

Safety Cable – Safety cables are recommended for all overhead vibrator installations.

Vacuum Mounting – For portable mounting of BH 1.62 & BH 2.00.

Bin Mapping Service

Vibration is effective in solving bulk material flow problems for several reasons.

There are two fundamental bulk material flow problems that are responsible for most applications of flow aid equipment in industry: Bridging and Ratholing – NAVCO Pneumatic Piston Vibrators are effective in solving both of these problems.

Bridging of material occurs when the cohesive strength of the bulk material is sufficient to form a bridge of material capable of supporting the column of material above it. Ratholing occurs when the sliding friction between the material and the vessel wall slows the flow of material in the outer perimeter of the vessel. The innermost material is able to flow through the central flow channel, and the outer material is restricted. Vibration, when applied properly, reduces the cohesive strength of the bulk materials and reduces sliding friction, thus eliminating the two major bulk material flow problems.

When an external vibrator is applied, the energy is transmitted through the vessel wall and the bulk material. The pattern and distance through which energy is transmitted is referred to as the “area of influence” of the vibrator.

The unique NAVCO Bin Map approach involves a detailed evaluation of the storage vessel and the bulk material. Based on a variety of factors including bulk density, particle size, moisture content, temperature, vessel size and shape, and material of construction, NAVCO pneumatic piston vibrators are sized for the application and their areas of influence are determined. The vibrators are then located on the vessel so that the areas of influence overlap, and they are controlled through a sequence to facilitate the optimum flow pattern and minimize utility consumption. The result is an effective solution to virtually any bulk material flow problem at a low initial and operating cost.

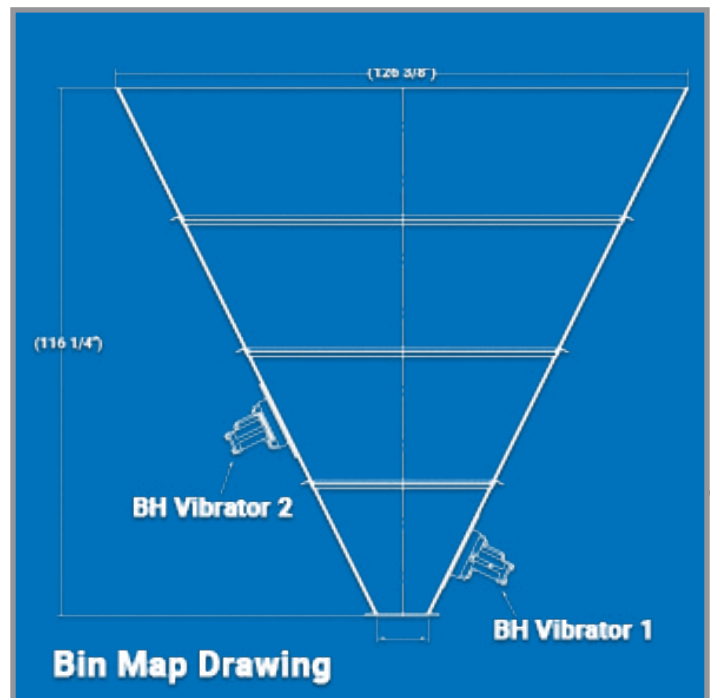

BH VIBRATOR GENERAL ARRANGEMENT

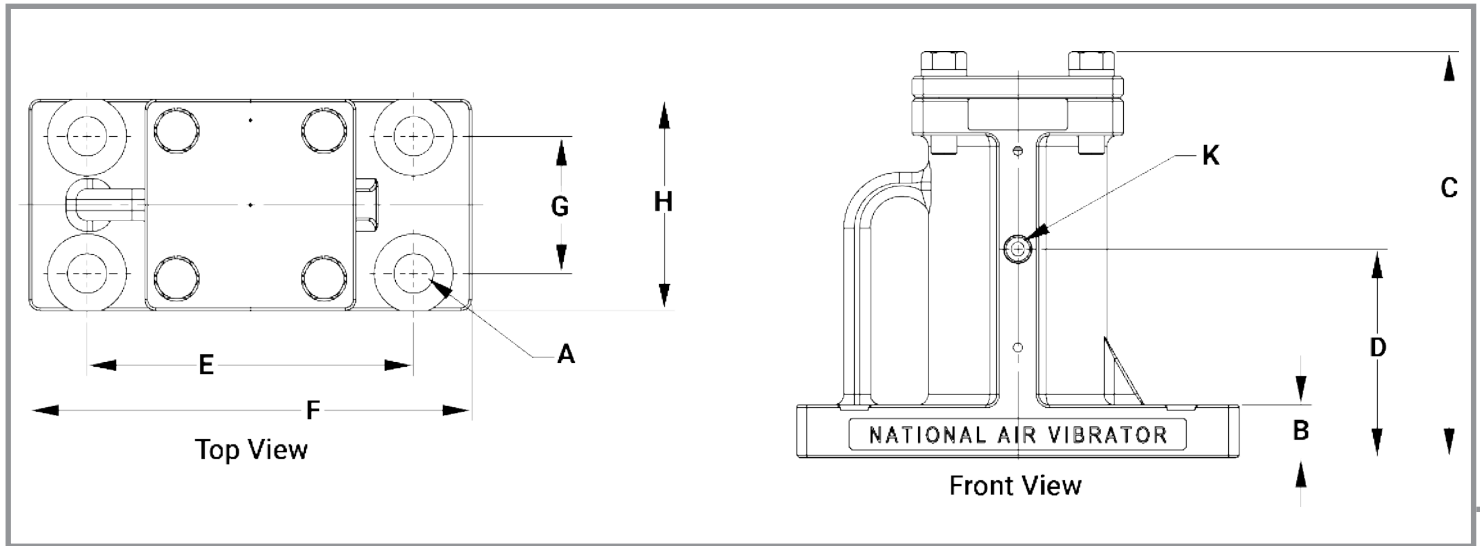

Model	A ¹ (in.)	B (in.)	C (in.)	D (in.)	E (in.)	F (in.)	G ² (in.)	H (in.)	K ³	Wt. (lbs)
BH 1.00	1/2	1/2	3-3/4	1-3/4	3-1/2	4-1/2	*	2	1/4	3
BH 1.25	1/2	3/4	5-5/8	3	4-1/2	6	*	2-1/2	1/4	8
BH 1.62	5/8	1	7-1/4	3-3/4	7-1/2	9	*	3-1/4	1/4	18
BH 2.00	5/8	1	7-1/4	3-3/4	7-1/2	9	*	3-1/4	1/4	20
BH 3.00	7/8	1-1/4	9-1/2	5	7-3/4	10-1/2	3-1/4	5	3/8	50
BH 3L	7/8	1-1/2	12	6-1/4	7-3/4	10-1/2	3-1/4	5	3/8	64
BH 4.00	1	1-1/4	11-3/4	5-7/8	12	14-1/2	4	6-1/2	1/2	105
BH 5.00	1	2	16-1/2	8-1/2	12	14-1/2	4	7-1/4	1/2	180
BH 6.00	1-1/2	2	19-1/2	9-7/8	11	14-1/2	7	10-1/8	1/2	350
BH 8.00	2	2-1/2	22-1/2	11-1/2	13	16-1/2	8-1/2	12-1/4	3/4	650

1. Mounting bolt diameter 2. * Asterisk indicates two bolt mount 3. Air inlet connection (NPT)

CONTACT US TODAY AT

E. SALES@NAVCO.US W. NAVCO.US A. 11929 Brittmoore Park Dr.
P. 832.467.3636 F. 832.467.3800 Houston, TX 77041