

# Extendovibe

## Extended Piston Vibrator for Unique Applications

The NAVCO Extendovibe was designed as a vibratory solution for unique applications. This extended piston vibrator can be used as a flow solution when other vibrators are not feasible due to inability to weld or other process limitations.

### Made in the USA

Made in the USA. NAVCO's pneumatic Extendovibe vibrators keep material flowing and processes going in unique applications across the US and the world.

### Multiple Industries

Agriculture, Energy, Construction, Pharmaceutical, Mining, Food Processing, Metal Manufacturing, and many more.

### Pneumatic (Air) Power to Fit Your Process

The Extendovibe is a pneumatic / air vibrator that is easily incorporated into existing industrial processes.

### High Amplitude, Low Frequency Vibration

The high-energy impulse from the high amplitude, low frequency vibration reduces the sticking strength of bulk materials and the sliding friction between the material and the container wall. This enables a consistent flow of materials through the container.

### Works on a Variety of Containers

Extendovibes have been utilized on a variety of containers including: Bulk Bags, Plastic Hoppers, Bins, Vessels, and Intermediate Bulk Containers (IBC).



### Improve Material Flow with Precise Problem Solving

The Extendovibe is positioned a ¼ to ½ inch from the surface to be impacted and functions by rapidly tapping an interchangeable rubber knob to the surface in a predetermined location. This effectively reduces the sliding friction and strength of the bulk material to allow for improved flow.

### A Vibrator for Portable Container Stations

The Extendovibe is ideal for applications where the containers are not captive to the process area. The vibrator is fixtured in the unloading station and the containers are placed against the vibrator during the unloading process. This reduces costs by allowing a single vibrator to be used across multiple containers, eliminating the need for individual vibrators on each container.

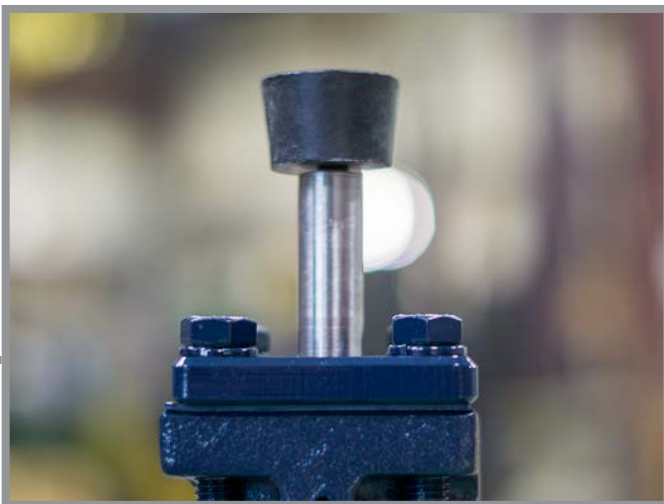

## CONTACT US TODAY AT

E. SALES@NAVCO.US

W. NAVCO.US

A. 11929 BRITTMOORE PARK DR.

P. 832.467.3636

F. 832.467.3800

HOUSTON, TX 77041

# Size and Dimensions

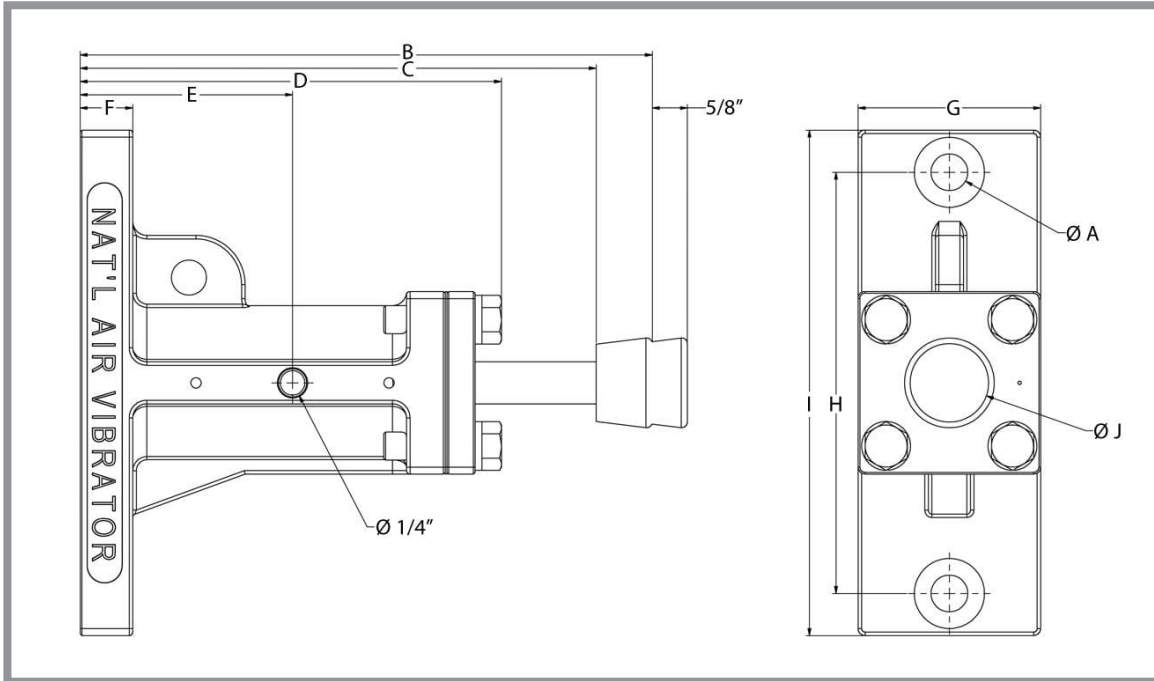

| Model    | A    | B*       | C       | D      | E      | F    | G      | H   | I  | J      | Rod Thread** | Wt. - lbs |
|----------|------|----------|---------|--------|--------|------|--------|-----|----|--------|--------------|-----------|
| EVH 1.25 | 1/2" | 6-6/13"  | 6"      | 5-5/8" | 3-3/4" | 3/4" | 2-1/2" | 8.8 | 6" | 1/2"   | 1/4"-20      | 8.8       |
| EVH 2.00 | 5/8" | 10-3/16" | 9-3/16" | 7-1/4" | 3-3/4" | 1"   | 3-1/4" | 20  | 9" | 1-1/2" | 5/16"-18     | 20        |

\* Length represents the rod retracted back. It will extend the listed 5/8" when operating.  
\*\* Female Thread

**CONTACT US TODAY AT**

E. SALES@NAVCO.US  
P. 832.467.3636

W. NAVCO.US  
F. 832.467.3800

A. 11929 BRITTMOORE PARK DR.  
HOUSTON, TX 77041