

Rotary Electric Vibrator

Power Vibratory Equipment and Material Flow Solutions

NAVCO® is the exclusive distributor for AVITEQ rotary electric vibrators, also known as unbalanced motors or electromechanical vibrators, for Canada, Mexico, and the United States. Available in a wide range of sizes and force outputs, these rotary electric vibrators can handle a wide range of applications. From light duty material flow solutions to powering heavy-duty vibratory equipment, NAVCO has the right rotary electric vibrator for your application.

Time Tested Industrial Electric Vibrators

With over 20 years' experience in partnership with AVITEQ, NAVCO supplies rotary electric vibrators (unbalanced motors) with a robust design and attention to detail. This combination ensures superior product quality and long operational life even in the toughest of conditions.

Driving Multiple Industries

Rotary Electric Vibrators can be found across a wide range of industries including:

Power / Coal	Mining & Aggregates
Chemicals & Pharmaceutical	Foods
Recycling	Plastics & Glass
Construction & Cement	& More

Electric Power

Electric vibrators designed for continuous duty operation.

- Centrifugal force range: 40 – 119,000 N
- Temperature range: -20 °C – + 40 °C / + 55 °C
(Contact NAVCO for special temperature options)
- Mains connection: Single and Three-phase for all conventional voltages
- 50 or 60 Hz models available



Hazardous Area Ready

Suitable for use in hazardous areas, there is a rotary electric vibrator model to meet the safety standards required in your application:

- CSA
 - Class 1 Div. 1, Class 1 Div. 2, Group A, B, C, D
 - Class 2 Div. 1, Class 2 Div. 2, Group E, F, G

- ATEX
 - Zone 21 & Zone 22
- IP 66 to EN 60529

Built For Continuous Operation

Vibrators that work as hard as you do. Designed for continuous operation Rotary Electric Vibrators keep up with your 24 hr. production process.

Adjustable Force Output

Rotary electric vibrators feature adjustable flyweights for force output adaptability. Fine-tune the force output of each motor to fit the specifications required by the task at hand.

Up to 27,000 Pounds of Centrifugal Force

Big challenges require big solutions. Our rotary electric vibrators provide up to 27,000 pounds-force. This makes them an ideal, low maintenance solution for driving large equipment.

Rotary Electric Vibrator

Vibration Technology for Processing Bulk Materials
Bulletin: 1000.201

Designed for Powerful and Reliable Performance

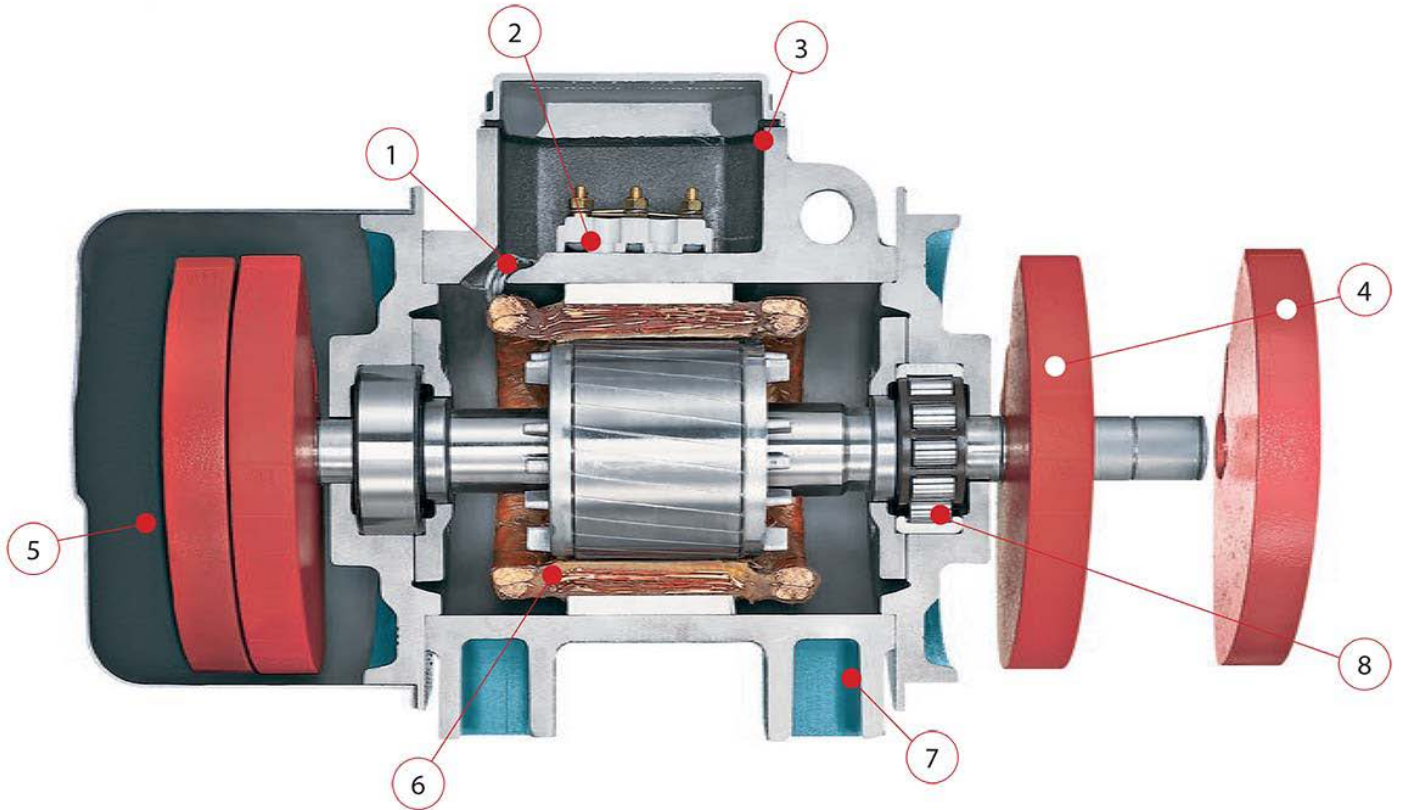

1. Thermistor

Thermistor protection as standard from model size UVA. Easy operation with speed controller.

2. Terminal Board

6-pin fully mounted (voltage up to 690V without additional insulation).

3. Cable Gland

Simple electric connection (IP 66), second separate cable gland for thermistor connection.

4. Unbalanced Weights

Adjustable and permanent legible setting scale that allow for quick and precise settings.

5. Cover

Easy handling. Dustproof and waterproof by o-ring flange seal.

6. Winding

Embedded in high quality resin; resistant to vibration, moisture and dust; armature shaft made of alloy steel.

7. Mounting

Tall feet for the extension of mounting screws; mounting in any position possible; suitable for high stress and large thermal reserve.

8. Ball-/Roller Bearings

Oversized ball-/roller bearings and continuous lubrication or re-lubrication option.

CONTACT US TODAY AT

E. SALES@NAVCO.US W. NAVCO.US

A. 11929 Brittmoore Park Dr.
Houston, TX 77041

P. 832.467.3636

F. 832.467.3800

NAVCO[®]
NATIONAL AIR VIBRATOR CO.

Updated: 02/2024

Rotary Electric Vibrator

Vibration Technology for Processing Bulk Materials
Bulletin: 1000.201

An Unbalanced Motor to Drive Vibratory Equipment

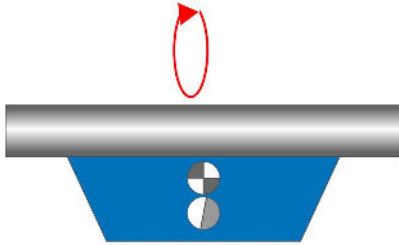

Elliptical Motion

A single drive unit mounted away from the center of gravity produces elliptical movement. This motion can be used for compaction or agitation on:

- Inclined screens
- Vibratory tables and packers
- Shakeouts
- Bin dischargers

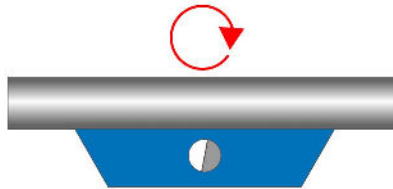

Circular motion

A single drive unit mounted at the center of gravity produces circular motion. This arrangement can be used to drive:

- Circular screens

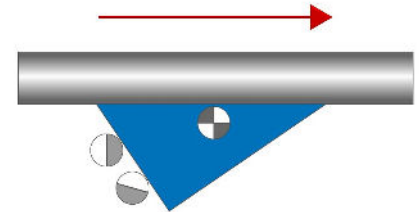

Linear motion

By using two motors, rotating in opposite directions and mounted on a common beam, linear motion is produced. This type of arrangement is used for:

- Feeders
- Screens
- Grizzlies
- Conveyors

Reliable and Low Maintenance

Designed to work, NAVCO Rotary Electric Vibrators are reliable, low maintenance electromechanical unbalanced motors. This combination makes them the ideal motor to drive vibratory equipment even in the toughest of environments.

Wide Range of Motor Sizes

From light duty to heavy duty applications, NAVCO has a Rotary Electric Vibrator to drive the vibratory equipment your process requires.

Replacement Vibrator Motors

With tall feet and a common bolt hole pattern, these vibrator motors can be easily swapped into existing applications as a high quality replacement for existing vibratory equipment.

Adjustable to the Application

Adjustable weights allow the motors to provide the precise vibration necessary to drive your vibratory equipment.

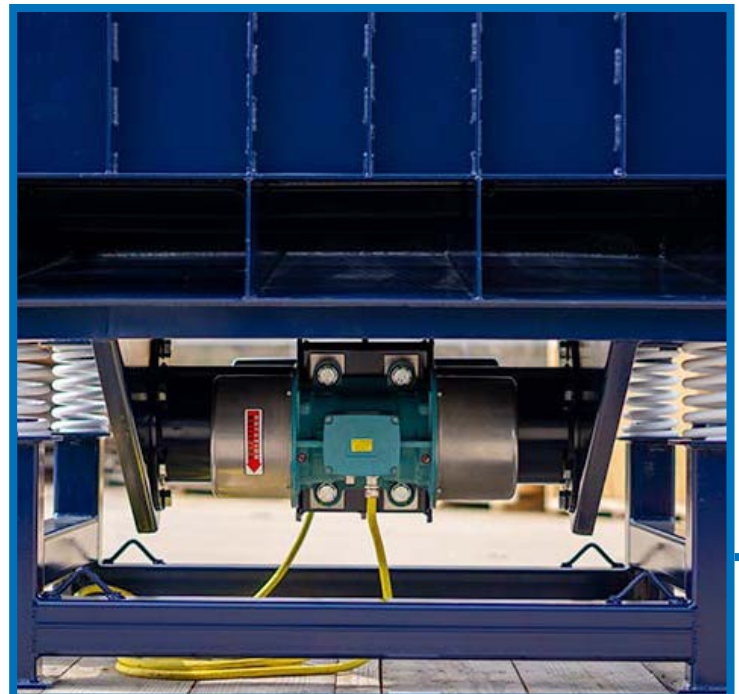

CONTACT US TODAY AT

E. SALES@NAVCO.US W. NAVCO.US

A. 11929 Brittmoore Park Dr.
Houston, TX 77041

P. 832.467.3636

F. 832.467.3800

NAVCO[®]
NATIONAL AIR VIBRATOR CO.

Updated: 02/2024

Rotary Electric Vibrator

Vibration Technology for Processing Bulk Materials
Bulletin: 1000.201

A Bin Discharge and Material Flow Solution

A Frequency and Amplitude for every problem

With numerous models to choose from and force output adjustability, these motors can be applied with precision to suit the exact requirements of the bin and material flow problem at hand. For assistance in sizing and applying, please contact NAVCO....

Reliable Material Flow

A rugged, industrial, and totally enclosed design offers long operating life even in harsh environments. Small to medium size models that are commonly utilized in flow aid applications to eliminate material bridging and rat holing.

Increased Safety, Less Noise

Motors produce low noise levels and arrangements are available for operation in hazardous environments.

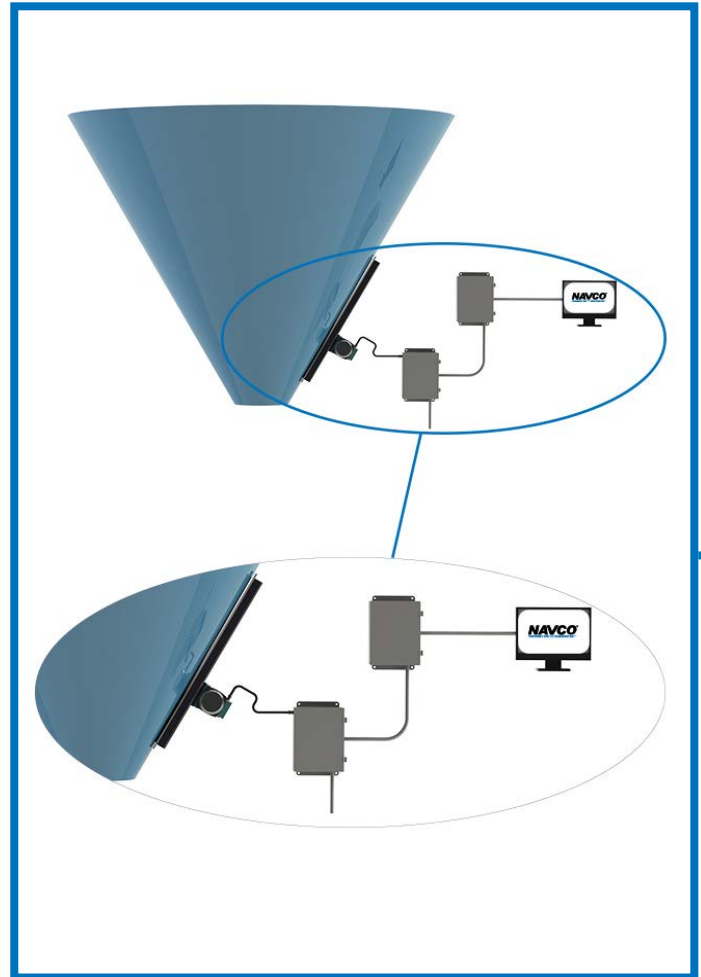

Rotary Electric Vibrator Accessories

- T-slot mounting plates
- Extended channel mounts
- Motor starters
- Thermistor monitoring relays
- Run capacitors
- Bearing grease

CONTACT US TODAY AT

E. SALES@NAVCO.US W. NAVCO.US

A. 11929 Brittmoore Park Dr.
Houston, TX 77041

P. 832.467.3636

F. 832.467.3800

NAVCO[®]
NATIONAL AIR VIBRATOR CO.

Updated: 02/2024

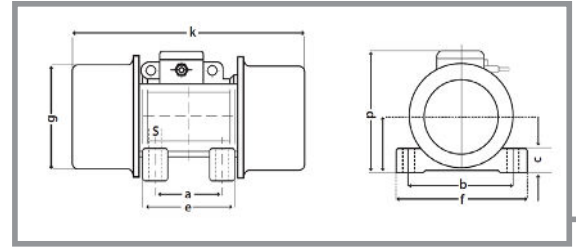

A Rotary Electric Vibrator for Every Application

Model #	Force	Working Moment	Weight	Rated Current	Power	Dimensions in Inches								Fasteners			
						a	b	c	e	f	g	h	k	p	s	Size	Number
3600 RPM	(lbs)	(in-lbs)	(lbs)	(A)	(HP)												
UV1A 0.04Y	13	0.10	1.9	0.3	0.03	1-1.5	2.9	0.4	2.0	3.5	2.2	1.2	4.1	2.7	0.22	M5	4
UVA 0.6Y	155	0.90	8.4	0.2	0.20	2.5	3.7	0.8	3.4	5.0	3.8	2.8	7.6	4.7	0.47	M8 (10)	4
FUVB 1Y	212	1.10	9.0	0.3	0.20	2.5-2.8	4.2	0.6	4.0	4.9	3.5	2.2	8.3	5.6	0.35	M8	4
FUVB 1.9Y	391	2.10	10.1	0.3	0.20	2.5-2.8	4.2	0.9	4.0	4.9	4.4	2.5	8.7	5.9	0.35	M8	4
FUVC 3Y	654	3.50	17.2	0.5	0.40	3.5	4.9	1.2	4.6	6.0	5.0	2.9	9.6	7.2	0.51	M 12	4
FUVD 5Y	1040	5.60	26.5	0.8	0.70	4.1	5.5	1.1	5.4	6.6	5.8	3.2	10.9	7.8	0.51	M 12	4
FUVE 7.7Y	1660	9.00	35.3	1.0	0.90	4.7	6.7	1.8	6.3	8.1	6.6	3.6	15.1	8.3	0.51	M 16	4
FUVE 11Y	2340	12.70	48.5	1.8	0.90	4.7	6.7	2.1	6.4	8.1	7.4	4.1	14.6	9.2	0.51	M 12	4
FUVF 20Y	4090	2.22	119.0	2.9	2.70	4.9	8.3	2.6	6.9	10.2	7.9	4.9	19.3	9.7	0.67	M 16	4
FUVG 32Y	7040	38.20	218.0	5.6	5.40	6.5	10.2	2.6	9.0	13.0	10.6	6.3	23.4	13.1	1.02	M 24	4
FUVH 40Y	9040	49.00	311.0	5.6	5.40	11.0	11.4	2.6	13.6	14.0	11.7	6.8	26.9	14.3	1.02	M 24	4
FUVL 62Y	14200	76.70	392.0	8.0	7.40	7.9	12.6	3.5	10.6	15.4	13.1	7.4	26.2	15.0	1.10	M 27	4
FUVL 88Y	19800	107.40	463.0	13.0	12.00	7.9	12.6	3.9	10.6	15.4	14.0	7.6	24.9	15.6	1.10	M 27	4
1800 RPM	(lbs)	(in-lbs)	(lbs)	(A)	(HP)	a	b	c	e	f	g	h	k	p	s	Size	Number
FUVB 0.3X	84	1.8	9.7	0.2	0.10	2.5-2.8	4.1	0.5	4.0	4.9	3.5	2.2	8.3	5.6	0.35	M8	4
FUVB 0.7X	172	3.6	11.7	0.2	0.10	2.5-2.8	4.1	0.9	4.0	4.9	4.4	2.5	8.7	5.9	0.35	M8	4
FUVC 1.5X	283	6.2	21.8	0.4	0.20	3.5	4.9	1.2	4.6	6.0	5.0	2.9	12.0	7.1	0.50	M 12	4
FUVC 2.1X	472	10.2	23.6	0.4	0.20	3.5	4.9	1.2	4.6	6.0	5.0	2.9	12.0	7.1	0.50	M 12	4
FUVD 4X	906	19.6	37.5	0.6	0.50	4.1	5.5	1.1	5.4	6.6	5.7	3.1	15.0	7.8	0.50	M 12	4
FUVD 5.4X	1306	28.2	41.9	0.6	0.50	4.1	5.5	1.1	5.4	6.6	5.7	3.6	15.0	7.8	0.50	M 12	4
FUVE 7X	1677	36.2	48.5	1.0	0.68	4.7	6.7	1.8	6.4	8.1	6.6	4.1	15.0	8.3	0.50	M 12	4
FUVE 10X	2165	46.9	68.3	1.0	0.68	4.7	6.7	2.1	6.4	8.1	7.4	4.9	17.0	9.2	0.50	M 12	4
FUVF 18X	3867	84.0	107.0	1.9	1.60	4.9	8.2	2.6	6.9	10.0	7.9	4.9	19.0	10.0	0.67	M 16	4
FUVF 24X	5395	116.9	145.5	3.0	2.30	4.9	8.2	2.6	6.9	10.0	9.1	5.5	21.0	11.0	0.67	M 16	4
FUVG 38X	8250	179.7	257.9	3.9	3.40	6.5	10.2	2.6	9.1	13.0	11.0	6.3	23.0	13.0	1.00	M 24	4
FUVH 49X	10903	352.7	352.7	5.0	4.60	11.0	11.4	2.8	14.0	14.0	12.0	6.8	27.0	14.0	1.00	M 24	4
FUVL 64X	14545	429.9	429.9	9.0	8.00	7.8	12.6	3.5	11.0	15.0	13.0	7.4	26.0	15.0	1.10	M 27	4
FUVN 83X	19670	668.0	668.0	12.0	11.40	9.8	14.9	1.4	13.0	18.0	15.0	8.5	34.0	17.0	1.50	M 36	6
FUVP 112X	25178	906.1	906.1	15.5	14.10	11.0	17.3	1.5	15.0	21.0	17.0	9.1	39.0	18.0	1.70	M 42	6

CONTACT US TODAY AT

E. SALES@NAVCO.US W. NAVCO.US

A. 11929 Brittmoore Park Dr.
Houston, TX 77041

P. 832.467.3636

F. 832.467.3800

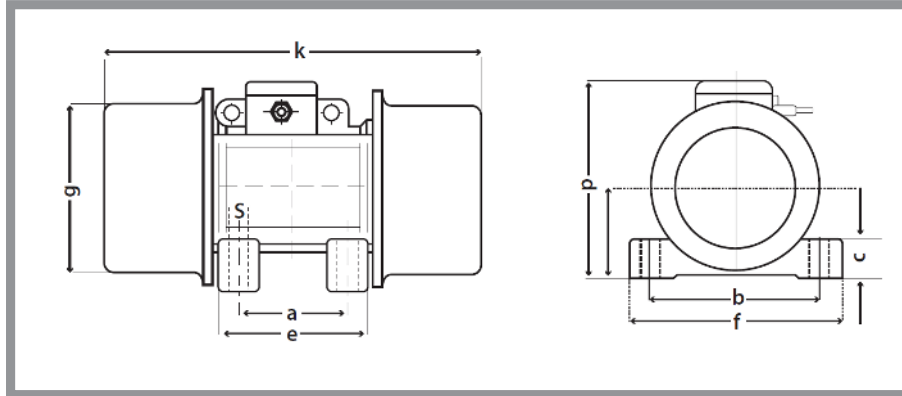

Model #	Force	Working Moment	Weight	Rated Current	Power	Dimensions in Inches										Fasteners		
						a	b	c	e	f	g	h	k	p	s	Size	Number	
1200 RPM	(lbs)	(in-lbs)	(lbs)	(A)	(HP)													
FUVE 3W	746	36.4	50.7	0.7	0.50	4.7	6.7	1.8	6.3	8.1	6.6	3.6	15.1	8.3	0.5	M 12	4	
FUVE 5W	1625	78.8	72.8	0.7	0.50	4.7	6.7	2.1	6.4	8.1	7.4	4.1	17.2	9.2	0.5	M 12	4	
FUVF 11W	2540	123.9	143.3	1.5	1.00	4.9	8.3	2.6	6.9	10.2	7.9	4.9	22.0	10.0	0.7	M 16	4	
FUVF 16W	3417	166.3	156.5	2.2	1.70	4.9	8.3	2.6	6.9	10.2	9.1	5.5	20.6	10.9	0.7	M 16	4	
FUVG 21W	6047	298.6	264.6	3.8	2.80	6.5	10.2	2.6	9.1	13.0	10.6	6.3	26.1	13.1	1.0	M 24	4	
FUVG 30W	6835	324.8	286.7	4.3	3.20	6.5	10.2	2.6	9.1	13.0	10.6	6.3	28.0	13.1	1.0	M 24	4	
FUVH 38W	8453	412.3	390.3	5.0	4.00	11.0	11.4	2.8	13.6	14.0	11.7	6.8	30.5	14.3	1.0	M 24	4	
FUVH 46W	10342	504.9	419.0	6.0	4.80	11.0	11.4	2.8	13.6	14.0	11.7	6.8	32.8	14.3	1.0	M 24	4	
FUVL 64W	14388	702.4	516.0	8.1	6.70	7.9	12.6	3.5	10.6	15.4	13.1	7.4	33.1	15.0	1.1	M 27	4	
FUVK 79W	17626	860	646.1	11.3	8.40	11.0	15.7	2.6	13.8	18.5	14.1	7.8	34.6	15.9	1.3	M 30	4	
FUVN 95W	20099	981.3	756.3	12.4	10.70	9.8	15.0	1.4	12.6	18.1	1.4	8.5	34.1	17.2	1.5	M 36	6	
FUVP 119W	26754	1306.9	981.2	15.0	12.70	11.0	17.3	1.5	14.6	20.9	1.5	9.1	39.1	17.9	1.7	M 42	6	
900 RPM	(lbs)	(in-lbs)	(lbs)	(A)	(HP)													
FUVF 6V	2022	175	161.0	1.3	0.70	4.9	8.3	2.6	6.9	10.2	7.9	4.9	22.0	9.7	0.7	M 16	4	
FUVF 9V	2927	253.8	182.0	2.2	1.50	4.9	8.3	2.6	6.9	10.2	9.1	5.5	23.7	10.9	0.7	M 16	4	
FUVG 14V	4647	402.7	286.7	4.2	1.80	6.5	10.2	2.6	9.1	13.0	10.6	6.3	28.0	13.1	1.0	M 24	4	
FUVH 21V	6835	592.4	390.3	5.2	3.10	11.0	11.4	2.8	13.6	14.0	11.7	6.8	30.5	14.3	1.0	M 24	4	
FUVH 26V	8397	728.4	465.0	6.0	4.00	11.0	11.4	2.8	13.6	14.0	11.7	6.8	32.8	14.3	1.0	M 24	4	
FUVL 36V	11660	1011.6	516.0	7.9	5.80	7.9	12.6	3.5	10.6	15.4	14.1	7.4	33.1	15.0	1.1	M 27	4	
FUVK 44V	14373	1246.3	720.0	9.5	7.80	11.0	15.7	2.6	14.0	18.5	14.1	7.9	34.6	15.9	1.3	M 30	4	
FUVN 76V	21915	1901.1	923.9	12.0	10.00	9.8	15.0	1.4	12.6	18.1	15.2	8.5	39.4	17.2	1.5	M 36	6	
FUVP 85V	24779	2148.8	1146.6	13.5	11.10	11.0	17.3	1.5	14.6	20.9	16.7	9.1	42.1	17.9	1.7	M 42	6	

Available in multiple supply voltages, contact NAVCO for further information.

Arrangements for hazardous/classified areas available (Ex. Class II Div. I, Class I Div. II, ATEX Zone 21 & Zone 22, etc.)

CONTACT US TODAY AT

E. SALES@NAVCO.US W. NAVCO.US

A. 11929 Brittmoore Park Dr.
Houston, TX 77041

P. 832.467.3636

F. 832.467.3800