

Overhead Railcar Shaker

NAVCO[®] Overhead Railcar Shakers are designed for unloading open-top hopper railcars in heavy-duty applications and harsh environments. It is sized to promote material flow where other railcar vibrators come up short. From frozen coal to excessive fines to excessive moisture from rain, the Overhead Railcar Shakers ensures bulk materials keep flowing in the toughest industrial applications.

Heavy-Duty Railcar Shaker, Made in the USA

Made in the USA, Overhead Railcar Shakers are designed to keep the toughest of material flowing out of open top bottom discharge hopper railcars.

Long Productive Operating Life

Designed with a heavy steel construction and minimal moving parts, this machine provides a long, reliable operating life in the toughest of conditions.

Working Across Many Industries

This railcar shaker can be found in many industries, including Aggregates, Power, Mining, Refining, and many more.

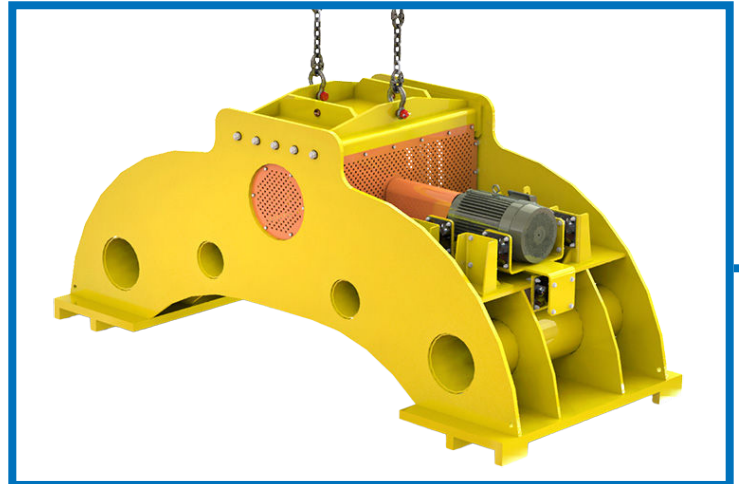

Key Features

Decrease Open-Top Hopper Railcar Unloading Times:

Overhead Railcar Shakers excel at decreasing railcar unloading times. The shaker creates a vibration response in the railcar that eliminates rat holes and bridging in tough material. From Coal to Coke to Aggregates to Asphalt, the Overhead Railcar Shaker gets your material flowing.

Safely Eliminate Costly Carryback :

Completely empty railcars and stop incurring costly carryback charges. Overhead Railcar Shakers utilize vibration to remove stubborn stuck material. This also increases personnel safety, as employees no longer need to enter the railcar to manually scrape the remaining material.

Ready for 24 Hour Days:

Designed to meet the needs of the heaviest of heavy-duty applications, Overhead Railcar Shakers are able to keep operating all day and night.



CONTACT US TODAY AT

E. SALES@NAVCO.US W. NAVCO.US

A. 11929 Brittmoore Park Dr.
Houston, TX 77041

P. 832.467.3636

F. 832.467.3800

Overhead Railcar Shaker

Vibration Technology for Processing Bulk Materials

Bulletin: 2000.301

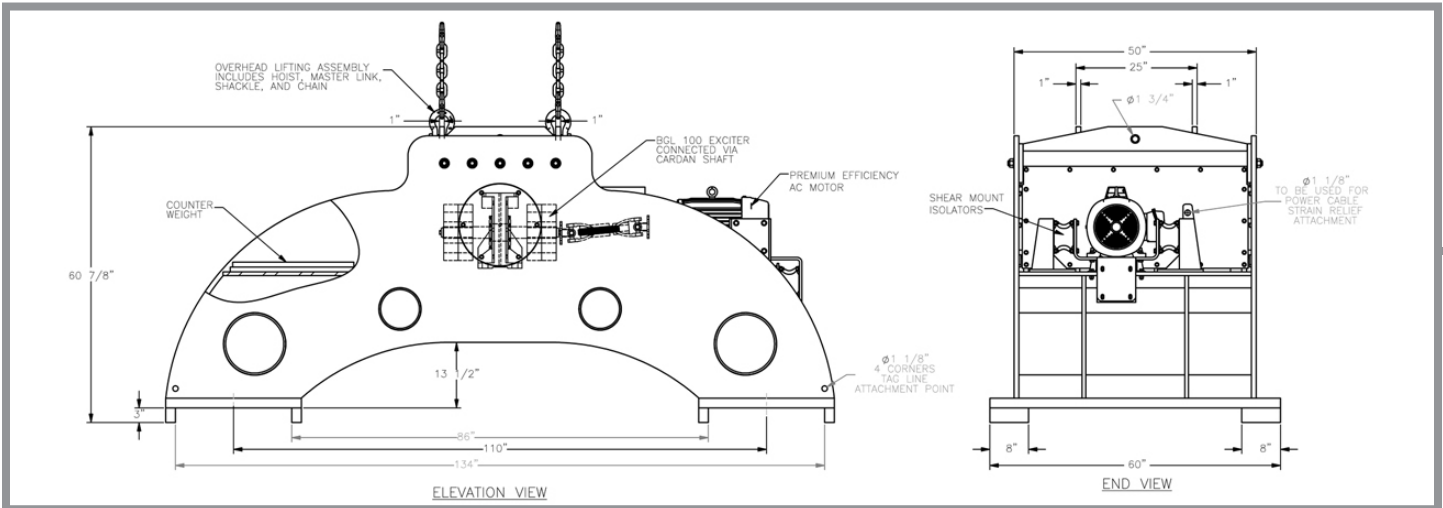

Controlled Vibration:

Variable frequency drive allows simple operating adjustments to meet the demand of changing unloading conditions.

Gear Box Exciter Drive:

It utilizes a modular sealed gear box exciter drive with close coupled bearings for low shaft deflection and long operational life.

Never Replace a Belt Again:

A direct coupled cardan drive shaft eliminates costly downtime associated with belt replacement, tensioning and maintenance needs.

Easy Maintenance Access:

Bolted modular components allow easy access for maintenance or replacement.

Customizable to Your Existing Railcar Unloading Facilities:

Have a facility with limited space? NAVCO can manufacture custom Overhead Railcar Shakers to meet the specific demands of your railcar unloading operation.

Specifications:

Total Weight

10,000 lb

Stroke

3-4 mm

Speed

Variable - Up to 1,200 RPM

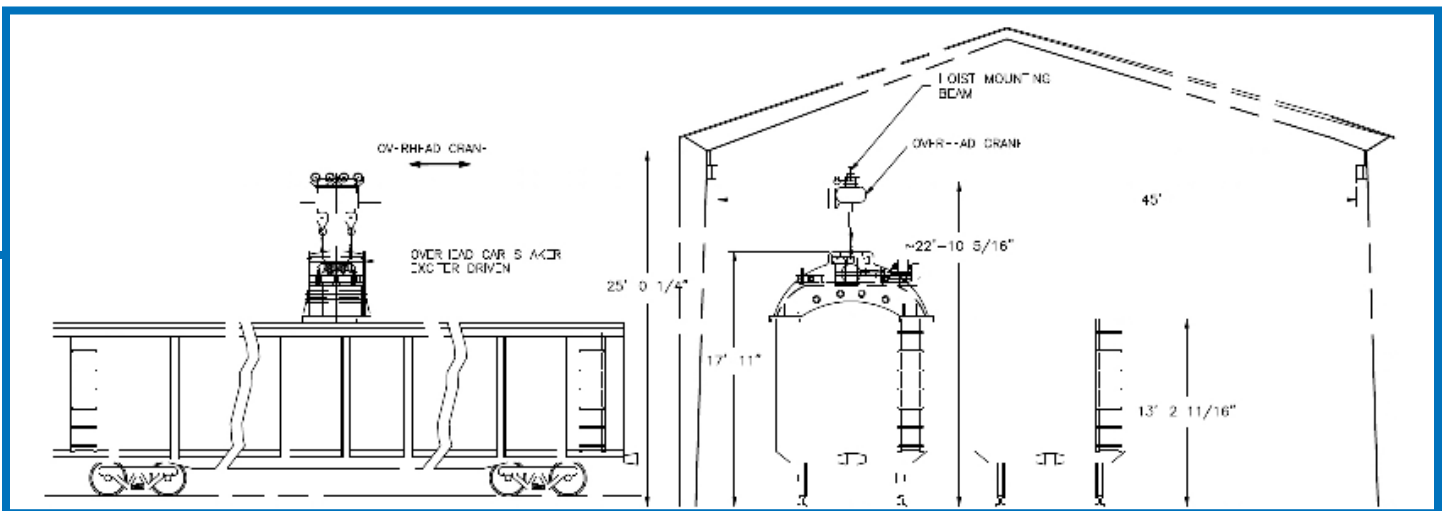

CONTACT US TODAY AT

E. SALES@NAVCO.US W. NAVCO.US

A. 11929 Brittmoore Park Dr.
Houston, TX 77041

P. 832.467.3636

F. 832.467.3800

NAVCO[®]
NATIONAL AIR VIBRATOR CO.